

Features:

- Hot-pluggable SFP+ footprint
- Supports 8.5 and 9.95 to 11.3 Gb/s
- Up to 80km link length
- 50GHz ITU-based channel spacing (C-Band) with a wavelength locker
- -40 to +85°C case temperature range
- Single 3.3V power supply
- Monolithic MZM Tunable TOSA
- Linear or Limiting electrical interface receiver
- Duplex LC connector
- Built-in digital diagnostic functions
- RoHS-6 compliant (lead-free)
- High Optical Output Power (min+3dBm)



Applications:

- DWDM 80km point to point links:
 - Remote PHY (R-PHY)
 - Wireless Backhaul
 - 10Gb/s SONET/SDH
 - 10G Ethernet
 - CPRI 7 and 8
 - 8G/10G Fibre Channel
- ITU-T G.698.1 DS100S1-2Dz(C)
- ITU-T G.709

1. Absolute Maximum Ratings

Exceeding the limits below may damage the transceiver module permanently.

Parameter	Symbol	Min	Typ	Max	Unit	Ref.
Maximum Supply Voltage	Vcc	-0.5		4.0	V	
Storage Temperature	TS	-40		85	°C	
Relative Humidity	RH	0		85	%	1
Receiver Optical Damage Threshold	RxDamage	5			dBm	

Note 1: Non-condensing

2. Electrical Characteristics

(TOP = -5 to +85 °C)

Parameter	Symbol	Min	Typ.	Max	Unit	Ref.
Supply Voltage	Vcc	3.14		3.46		
Supply Current	Icc			910	mA	1
Module total power dissipation	P			3.0	W	2
Transmitter						
Input differential impedance	Rin	80	100	120	Ω	
Differential data input swing	Vin,pp	200		850	mV	3
Transmit Disable Voltage	VD	Vcc-0.8		Vcc	V	
Transmit Enable Voltage	VEN	Vee		Vee+ 0.8	V	
Receiver						
Output differential impedance	Rout	80	100	120	Ω	
Differential data output swing	Vout,pp	100		850	mV	4
Output rise time and fall time	Tr, Tf	28			ps	4,5
LOS asserted	VLOS_A	Vcc-0.8		Vcc	V	
LOS de-asserted	VLOS_D	Vee		Vee+0.8	V	
Power Supply Noise Tolerance	VccT/VccR	Per SFF-8431 Rev 4.1			mVpp	

Notes:

1. Compliant with the SFP+ Module Power Supply Requirements defined in SFF-8431.
2. Maximum total power value is specified across the full temperature and voltage range.
3. Connected directly to TX data input pins.
4. Into 100Ω differential termination.
5. 20 – 80%. Measured with Module Compliance Test Board and OMA test pattern. Use of four 1's and four 0's sequence in the PRBS 9 is an acceptable alternative. SFF-8431 Rev 4.1.

3. Optical Characteristics

(TOP = -5 to +85 °C, VCC = 3.14 to 3.46 Volts)

Parameter	Symbol	Min	Typ	Max	Unit	Ref.
Transmitter (Tx)						
Average Launch Power	PAVE	+3			dBm	
Optical Wavelength	λ_c	As per ITU-T 694.1, 50GHz spacing 1528.77 to 1563.86			nm	
Side-Mode Suppression Ratio	SMSR	30			dB	
Optical Extinction Ratio	ER	8.2			dB	
Average Launch power when Tx is OFF	POFF			-30	dBm	
Tx Jitter 20kHz - 80MHz	Txj1			0.3	UI	
Tx Jitter 4MHz - 80MHz	Txj2			0.1	UI	
Relative Intensity Noise	RIN			-128	dB/Hz	
Center Wavelength	Beginning of Life	λ_c_BOL	z-1.5	z	z+1.5	GHz
	End of Life	λ_c_EOL	z-2.5	z	z+2.5	GHz
Receiver (Rx) at 0ps/nm						
Bit rate	BER					
8.5, 9.95	<1E-12	RSENS1			-24.0	dBm 1,2
10.7 Gb/s	<1E-12	RSENS2			-23.0	dBm 1,2
11.1 Gb/s	<1E-4	RSENS3			-27.0	dBm
11.3 Gb/s	<1E-4	RSENS4			-27.0	dBm
Overload (Average Power)	PAVE			-7	dBm	
Optical Center Wavelength	λ_C	1260		1600	nm	
LOS De-Assert	LOSD			-25	dBm	
LOS Assert	LOSA	-34		-27	dBm	
LOS Hysteresis	LOSH	0.5			dB	
Receiver Reflectance	Rrx			-27	dB	

Receiver Sensitivity³					
Data rate (Gb/s)	BER	Dispersion (ps/nm)	Sensitivity back-to-back at OSNR>30dB (dBm)	Dispersion Penalty at OSNR>30dB (dB)	Threshold Adjust Required
9.95	1e-12	-300 to 1450	-24	2	No
10.3	1e-12	-300 to 1450	-23	2.5	No
10.7	1e-4	-300 to 1300	-27	3	Yes
11.1	1e-4	-300 to 1300	-27	3	Yes

OSNR Performance ⁴					
Data rate (Gb/s)	BER	Dispersion (ps/nm)	Min OSNR Back-to-back at Power: -18dBm to -7dBm (dB)	Max OSNR Penalty at Power: -18 to -7dBm (dB)	Threshold Adjust Required
9.95	1e-12	-300 to 1450	24	4	Yes
10.3	1e-12	-300 to 1450	24	4	Yes
10.7	1e-4	-300 to 1300	16	4	Yes
11.1	1e-4	-300 to 1300	16	4	Yes

Notes:

1. Measured with worst ER=8.2dB; BER<10⁻¹²; 2³¹ - 1 PRBS.
2. For 10GEthernet application, -24dBm is equivalent to an OMA of -22.09dBm for an ER = 8.2 dB.
3. Measured at 1528-1600nm with worst ER; PRBS31.
4. All OSNR measurements are performed with 0.1nm resolution.

4. General Specifications

Parameter	Symbol	Min	Typ	Max	Units	Ref.
Bit Rate	BR	8.5		11.3168	Gb/s	1
Max. Supported Link Length	LMAX			80	km	2

Notes:

1. Tested with a 2³¹ - 1 PRBS pattern at the BER defined in Table 4.
2. Over G.652 single mode fiber.

5. Mechanical Diagram

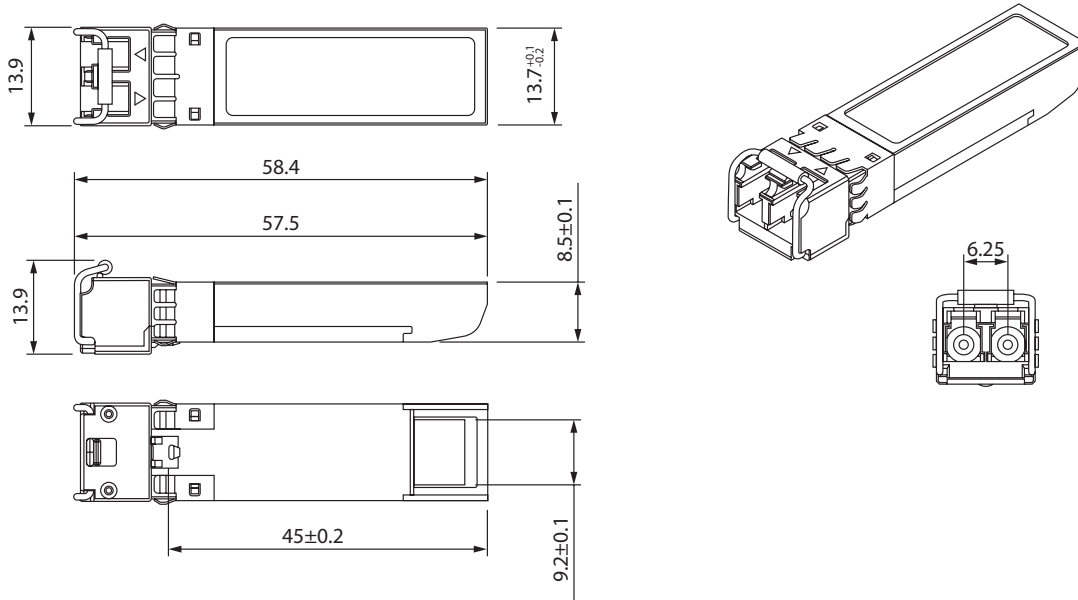

Note: External physical characteristics are subject to variation. This may include, but is not limited to, external case designs, pull tab colors and/or shapes, removal latch styles or colors, and label sizes and placement. These variations do not affect the function or characteristics of the transceivers.

6. Ordering Information

OEM	Part Number	OEM	Part Number
MSA	AN-SFPP-TUNE-3DB-I	OnePort	OP-SFPP-TUNE-3DB-I

7. Contact Information

Tel: 800.590.9535

Web: <http://www.approvednetworks.com>